

SALTO NEOXX - ELECTRONIC PADLOCK

The SALTO Neoxx electronic padlock's new features and enhancement keep it at the cutting edge of the security industry and access control ecosystem.

Power for every access, technology for any application.

SALTO
inspiredaccess

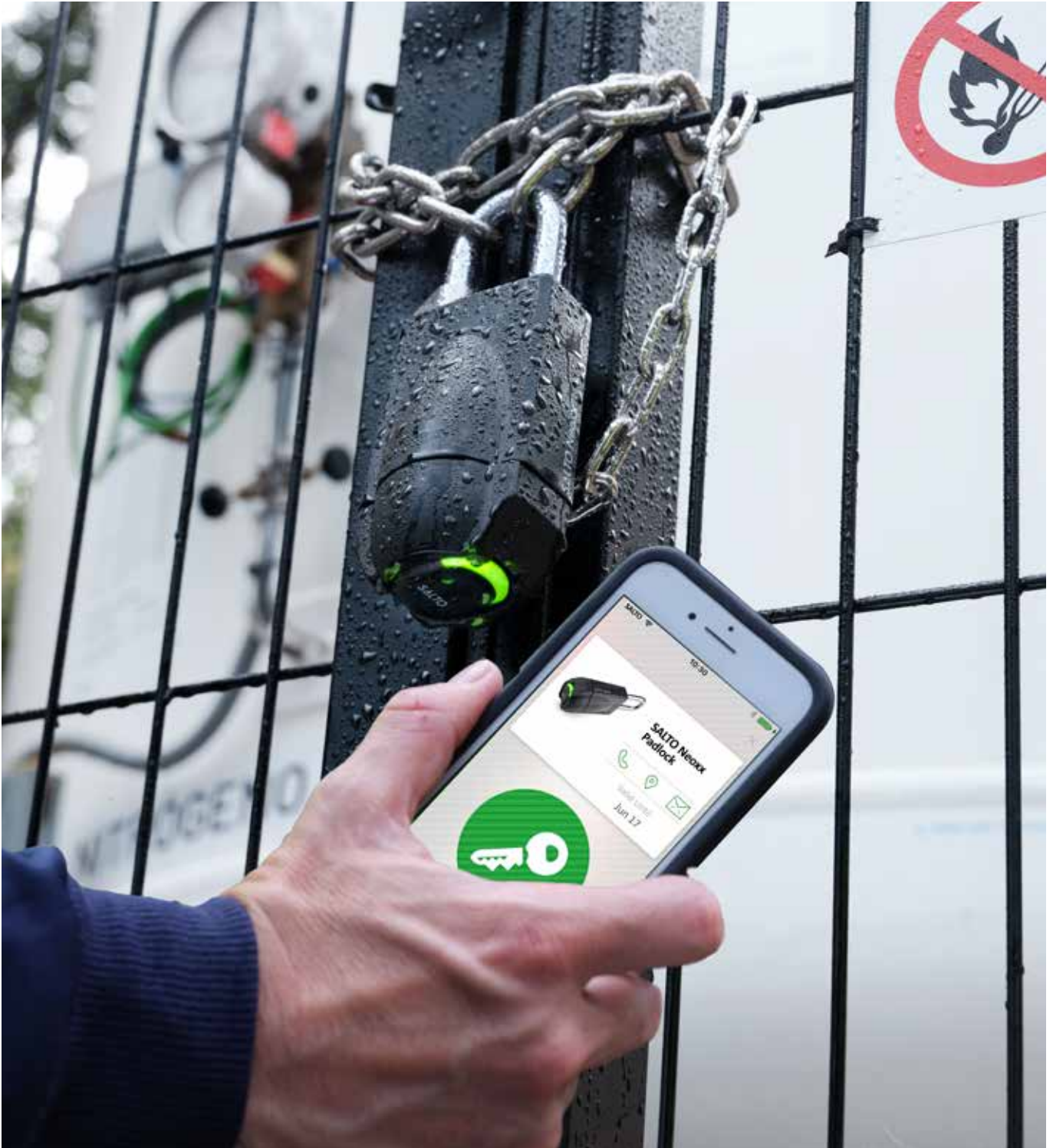

Telephone: 1300 723 796

Email: sales@safeguardlocksmiths.com.au

Website: www.safeguardlocksmiths.com.au



ELECTRONIC PADLOCK SALTO NEOXX



BUILT TO WITHSTAND ALL ACCESS NEEDS, UNLOCK SMARTER WITH THE TOUGH NEW SALTO NEOXX ELECTRONIC PADLOCK.

SALTO Systems has invested years of working with some of the best minds in the security industry – our community of security specifiers and installers – to build the most reliable and smartest electronic padlock on Earth. With exceptional attention to detail, premium materials, and all SALTO technology inside – SALTO Neoxx – looks great while packing technological power.

The SALTO Neoxx Padlock offers a unique solution ideal for utility providers – electric power stations, telecom network services, industry applications, and more – and property services that need an additional level of security to control specific doors like gates or storages, without losing a piece of convenience and control. These industries oftentimes require equipment and facilities on the perimeter or out in the field that, even though they are in a remote location, require the latest in electronic access control. And because they are often outdoors, the electronic solution they need has to include a product that can weather the extreme elements.

Manage the security of your site 24/7 easily with an advanced, reliable electronic locking technology that meets all of the security requirements and more. Ensure facility security and accessibility to efficiently manage your building while providing a better user keyless and mobile experience.



ULTIMATE PROTECTION

The SALTO Neox Padlock's innovative **special armoured case** with double-layered structure guarantees the ultimate protection from falls, shocks, and the hardest environment or usage.



TECHNOLOGY AND DESIGN

Exceptional attention to detail, premium materials, and all SALTO technology inside.

Compatible with **SALTO SPACE – Data-on-Card–** and the **SALTO KS – Keys as a Service – cloud-based technology.**



SMART KEY

Easy-to-use and highly secure keyless technology provides instant and reliable access to any door. Combine the advantages of **RFID (DESFire EV1 EV2, MIFARE, HID iCLASS Seos), BLE (Bluetooth Low Energy) and NFC technologies.** End users can easily operate the padlock with their smart card or with their iPhones or Android phones.



TESTED AND APPROVED

Attack resistance: Mechatronic certification EN16864:2018.

IP66 certification: Waterproof performance and high durability.

Tested against extreme temperatures: Including freezing conditions (-35°C) and high heat (+65°C).

Tested up to **130,000 operations** on a standard set of batteries (4 x LR1).

Certified according to CE, FCC, MIT, and IK09.



WATERPROOF & SHOCKPROOF

UNLOCKING A SMARTER PADLOCK AND PROVIDING THE ULTIMATE PROTECTION CHASSIS

The SALTO Neoxx Padlock's innovative special armoured cover case with double-layered structure guarantees the ultimate protection from falls, shocks, and the hardest environment or usage. There is also an additional UV protection to withstand the solar impact. The reinforced bumpers around the body protect the most sensitive parts of the padlock and absorb the energy of any fall, protecting the electronics and the mechanics to maintain the operability making it both robust and all-weather resistant.

Built to withstand every application, tested and approved, the SALTO Neoxx is a padlock you can rely on when you're out in the field in any type of application. Robust and durable, this electronic padlock features IP66 water resistance and dust protection for harsh environments and extreme climates, to shield it from the elements.

The cover is perfectly aligned over the body. A smart reader opening mechanism on the padlock provides a comfortable opening and ensures a perfect and secure closing. A self-locking mechanism ensures that when closing the shackle, the padlock will always automatically be locked.

ROBUST AND RELIABLE:

The SALTO Neoxx is a high-security padlock made of hardened steel with a removable shackle model option, which can be completely detached from the padlock body.

Shackle: Width 11mm - Length 50mm

Security chain non-dismountable model with safety-chain to protect the padlock from burglary/dropping.

Cover case with double-layered structure 70mm x 174mm x 32mm guarantees the ultimate protection from falls, shocks, and the most extreme environments or usage.

IP66 certification: Waterproof performance and high durability.

Tested against extreme temperatures: Including freezing conditions (-35°C) and high heat (+65°C).

Fully certified according to CE, FCC, MIT, Mechatronic certification EN16864:2018 and IK09.



IP66

SMART ACCESS

A HIGH-PERFORMING, SMARTER, KEYLESS, AND MOBILE ACCESS EXPERIENCE

The SALTO Neoxx sets a new bar for connectivity in access control. It packs the latest BLUEnet Wireless cutting-edge real-time technology, more functionality, and performance capability, allowing businesses to connect to their on-premise network via advanced SVN technology or to the cloud with the SALTO KS cloud-hosted access management platform. Access rights of lost, stolen, or unreturned keys can be quickly and inexpensively removed from the system and/or digital keys can be issued immediately to the user's mobile out in the field.

SALTO JustIN Mobile technology is onboard every SALTO Neoxx electronic Padlock. This gives users and system administrators the capability to send or receive a mobile key to open any door or gate with an installed SALTO Neoxx Padlock with their iOS or Android Bluetooth or NFC-enabled smartphone.

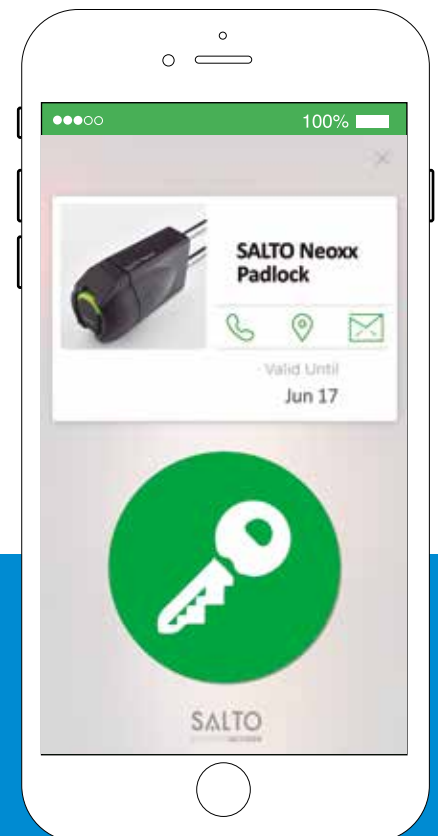

SMART KEY:



CONTACTLESS

Increase flexibility and improve security. Easy, efficient, and intuitive automated key delivery to create unique keyless experience.



DIGITAL KEY

Proven mobile and secure technology to create unique keyless experience anytime, from anywhere, and on any device.



SMARTER ACCESS

Send or receive a secure key to open any door. Issue, cancel, and restrict keys to specific times and locations.

Incorporating keyless access and JustIN Mobile technology into building security ecosystems without jeopardizing security is essential to maintaining safety. Technologically cutting-edge, SALTO's access control solutions means the end of lost key hassles and expense:

- Up-to-date access rights directly into the user's smartphone
- Dynamic user key management
- Automatic key renewal and cancellation
- User key instant cancellation
- Update the lock's denylist via a mobile phone

SVN

Take data-on-card even further

Easy-to-use technology that integrates all physical security needs through networked, stand-alone, battery-operated smart electronic Padlocks.

Efficiently use the natural movements of different groups of users within and across the individual areas of the facility to update the door network.

Based on SALTO's BLUEnet wireless communications technology and SVN core technology, SVN-Flex extends and increases the number of updating points directly to any Padlock in a building.

BLUEnet Wireless

Take advantage of the same secure infrastructure

SALTO BLUEnet Wireless generation was developed to meet the highest demands related to security, connectivity, and cross-platform capabilities and has now been successfully extended to the SALTO Neoxx Padlock product range.

Provides administrators with the real-time view of every SALTO Neoxx Padlock with available reports and log files of each individual access point deployment, the ability to control remotely, firmware update capability, remote opening, emergency opening, lockdown capability and the ability to easily control all access and building user management needs.

JustIN Mobile

Open smarter with mobile key

The SALTO Neoxx Padlock is JustIN Mobile compatible which means that any user can use a smartphone (iOS or Android) to operate the lock.

Adding JustIN Mobile functionality to an electronic cylinder means adding more features that can be conducted over the phone network, like: **updating credentials; denylist transmission; automatic audit trail collection; and automatic battery status collection.**



SMART ACCESS

POWER FOR EVERY ACCESS, TECHNOLOGY FOR ANY APPLICATION

With a long-lasting performance on just a standard set of batteries (4 x LR1), the SALTO Neoxx electronic padlock gives you the power you need to maintain your installation. Low battery status capabilities monitor your electronic padlock battery levels to make more efficient access management, minimize lifecycle costs, and reduce maintenance costs.

The SALTO Neoxx Padlock is outfitted with a suite of SALTO applications and is fully compatible with the rest of the SALTO smart electronic hardware locking platform. This provides the ability to integrate all of your physical security needs through smart, wireless, and battery-operated smart door locks, giving system operators all the latest user access information for virtually all of the doors in a facility.

With the new SALTO Neoxx Padlock, the suite of SALTO products delivers the most complete locking platform on the market — electronic locks and cylinders, online readers, and locker locks. Complete hardware and electronic locking platform, which fits virtually any door and any access point with an advanced, reliable electronic locking technology that meets all of the security requirements and more. Ensure facility security and accessibility to efficiently manage your facility while providing a better user keyless and mobile experience.

Low battery status capabilities monitor your electronic padlock battery levels to make more efficient access management, minimize lifecycle costs and reduce maintenance costs.





Easy to operate with state-of-the-art technology – for the ultimate protection and maximum convenience.



SALTO NEOXX PADLOCK

SPECS

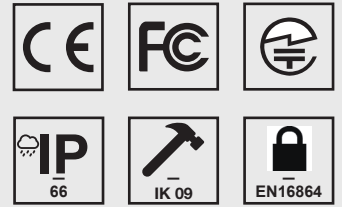

DATASHEET

SALTO NEOXX ELECTRONIC PADLOCK

Fully integrated with the SALTO SPACE and SALTO KS platforms, the SALTO Neoxx padlock is a versatile, cost-effective electronic padlock with a robust design that brings the latest technology to your SALTO access control system.

TECHNICAL DATA:

Housing dimensions:	70mm x 174mm x 32mm
Shackle length:	50mm
Shackle width:	11mm
Weight:	1.065g
IP class:	Outdoor version IP66
Certifications:	CE, FCC/IC, RCM, MIC, IK09, EN16864:2018
Power source:	4 LR1 alkaline batteries *
Number of openings:	Up to 130.000
Maximum events on lock audit:	Up to 2.200 (non volatile memory)
Environmental conditions:	-35°C/ +65°C (without condensation)

* SALTO recommends to use specific batteries brands and models to ensure a correct battery life, please consult SALTO.

ID TECHNOLOGIES:

MIFARE:*	•
BLE Smart:	•
NFC:	•
Legic:**	—
HID iCLASS® Seos™:	•
Picopass:	—

* MIFARE® (DESFire EV2, Plus, Ultralight C, Classic - ISO/IEC 14443)

** Legic Prime and Legic Advant

TECHNOLOGY PLATFORMS:

SALTO SPACE:

Smile - Selfprogrammable	—
ROM:	—
SVN data-on-card:	•
SALTO Wireless RFnet enabled:	—
SALTO Wireless BLUEnet enabled:	•

SALTO KS:

SALTO KS:	•
-----------	---

SALTO SALLIS:

SALLIS:	—
---------	---

TECHNICAL DRAWING:

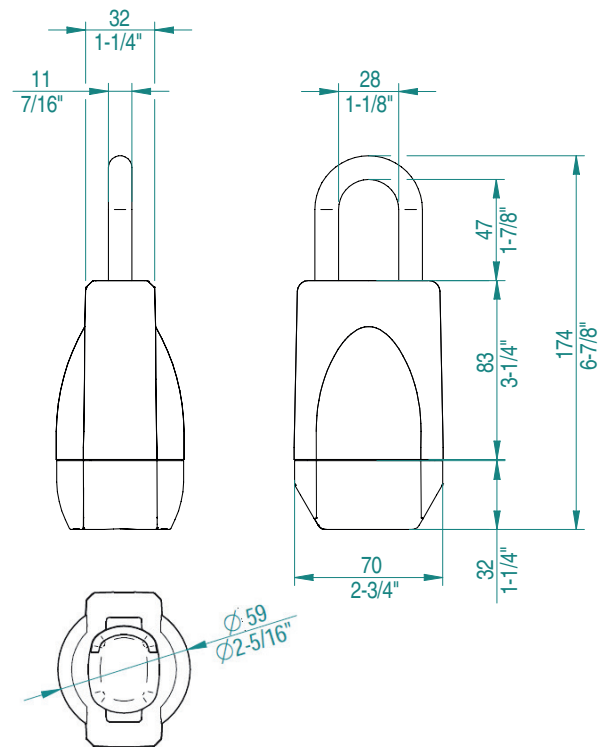

OPENING MODES:

Standard:	•
Office mode:	•
Timed office:	•
Automatic opening:	•
Automatic opening + office	•
Toggle:	•
Timed Toggle:	•
Amok mode:	—
Exit leaves open mode:	—

OPTIONS:

READER COLOUR:

Black:	•
White:	—

FINISHES:

Satin chrome	—
Polished chrome	•
PVD bright brass type	—
PVD satin brass type	—
Satin chrome black	—
BioCote® (Satin chrome)	—
Housing colour.	•
Black mat (Rubber finish)	•

¹ depending on the programming mode

